

# Product Overview

SSI SCHAEFER Plastics  
Waste Management & Recycling

[ssi-plastic.com](http://ssi-plastic.com)



# SSI SCHAEFER Plastics WASTE MANAGEMENT & RECYCLING

The internationally active SSI SCHAEFER Plastics GmbH is a leading provider of innovative container systems, constructive packaging, waste technology and recycling solutions. The company is part of the SSI SCHAEFER Group and employs more than 1,000 people worldwide.

In addition to the continuous development of the existing product portfolio, the growth of new approaches to the digitalization of waste management and the claim of high environmental compatibility of the products in order to conserve resources and reduce the CO<sub>2</sub> footprint are anchored in the company strategy.



For decades, SSI SCHAEFER Plastics has been trendsetting in the development of novel disposal systems and is setting new standards in waste management with innovations and high quality products and processes. The SSI SCHAEFER Plastics experts design comprehensive, system solutions and modular concepts, which can be optimally implemented into already existing customer structures.

## OUR BRAND

**AS A FAMILY-RUN COMPANY, WE COMMITTED OURSELVES TO CLEAR VALUES AND CONVICTIONS FROM DAY ONE. THEY SHAPE OUR CHARACTER, MANIFEST THEMSELVES IN OUR CULTURE, OUR ATTITUDE, THE WAY WE WORK AND WHAT WE OFFER.**

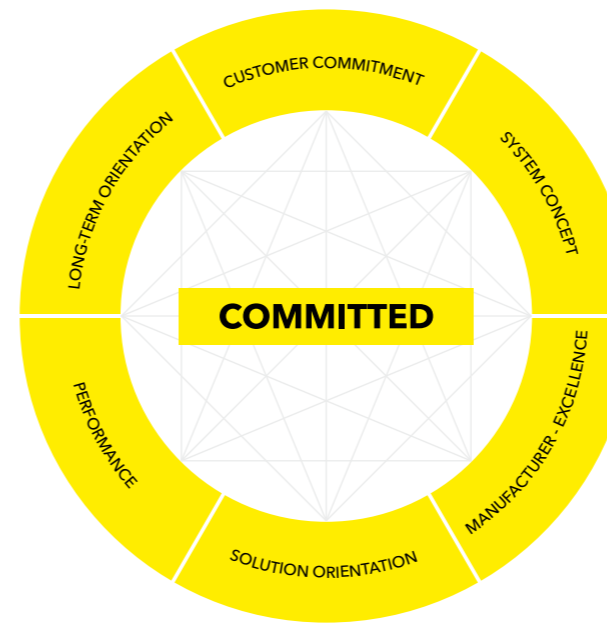

- Customer Commitment**  
 Our primary commitment is always to our customers, to whom we always put first.
- System Concept**  
 We offer tailor-made, modular solutions from a single source.
- Manufacturer - Excellence**  
 We deliver the highest quality through our own development and production of our products.
- Solution Orientation**  
 We always want to find the best solution for the customer.
- Performance**  
 We are there for our customers - worldwide and with maximum investment strength.
- Long-Term Orientation**  
 As a financially independent family business, we think long-term and as such are here for our customers tomorrow, and the day after tomorrow, and the day after that.

## Container Production

In our own production SSI SCHAEFER Plastics develops and produces certified containers made of steel and plastic, which are intended for the collection and transport of solid waste for all requirements and in all sizes. The quality management according to DIN ISO 9001 and RAL Quality Mark ensures a high reliability and stability of our products.

## Digitalization Of Waste Management

Since 2015, digital solutions for the disposal industry complete the product portfolio. The solutions offer analysis of requirements, software and hardware solutions and an cloud-based online platform for citizens, industry and commerce, as well as for waste disposal companies and municipalities. Networking and transparency are more important than ever in the context of digitalization.



# Plastic Containers

60 – 360 litres

- Made of High Density Polyethylene, HDPE
- Excellent equipment for the latest emptying devices
- Trouble-free use
- Long service life
- Prepared for the fitting of chips for identification and weighing
- Reinforced wheel housing and wheel support
- Various versions available: from standard bin to the thoroughly ventilated version
- UV-stabilised
- Manufactured according to DIN EN 840 - 1, 5 and 6, DIN 30760
- Ergonomically positioned handles
- Lid with surrounding drip edge for condensation
- RAL Quality Mark approved acc. To RAL-GZ 951 / 1 for bins according to DIN EN 840
- Axle made of quenched and tempered steel
- External wheels (not integrated) for high stability
- Noise reduced <92dbA according to the EU Directive 2000 / 14 / EG
- Lid opening damping for standard version
- Additional supporting rib
- Integrated chipnest for transponder

## PRO WAVE

PRO Wave	60 l	80 l	120 l	240 l
Width mm (W)	446	448 ± 5	480 ± 5	580 ± 5
Height mm (H)	922	1,005 max.	1,005 max.	1,100 max.
Depth mm (D)	514	530 max.	555 max.	740 max.
Nominal volume l	60 +13 / -5	80 + 18 / -5	120 + 8 / -6	240 + 15 / -5
Payload kg	40	40	48	96
Wheel - Ø mm	200	200	200	200

All dimensions are nominal in accordance with DIN EN 840.

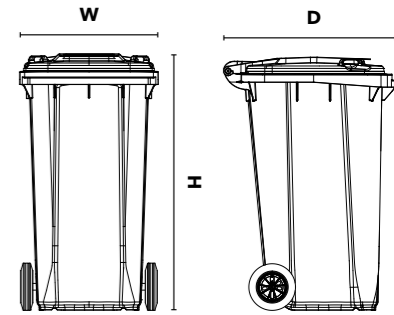

## GMT eXtra

GMT eXtra	120 l	140 l	180 l	240 l	360 l*
Width mm (W)	505 max.	505 max.	505 max.	580 +5 / -5	685 max.
Height mm (H)	1,005 max.	1,100 max.	1,100 max.	1,100 max.	1,115 max.
Depth mm (D)	555 max.	555 max.	755 max.	740 max.	880 max.
Nominal volume l	120 +8 / -6	140 +6 / -12	180 +40 / -10	240 +15 / -5	360 +20 / -40
Payload kg	48	56	72	96	144
Wheel - Ø mm	200	200	200/250	200	200 / 300

All dimensions are nominal in accordance with DIN EN 840, colours are subject to deviation.

\*Type: Smooth body version

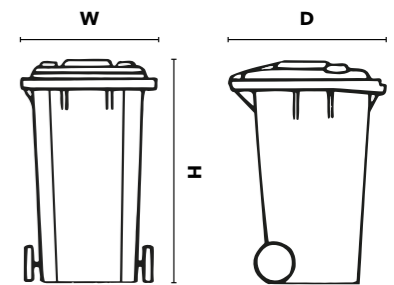

## DIAMOND REFUSE CONTAINERS

DU - Container*	120 l	140 l	180 l	240 l	360 l
Width mm (W)	500 max.	500 max.	500 max.	585 max.	660 max.
Height mm (H)	952 max.	1,085 max.	1,085 max.	1,085 max.	1,096 max.
Depth mm (D)	610 max.	610 max.	785 max.	795 max.	955 max.
Nominal volume l	120 + 15 / -5	140 + 15 / -5	180 + 15 / -5	240 + 15 / -5	360 + 40 / -5
Payload kg	48	56	72	96	144
Wheel - Ø mm	200	200	200/250	200	200 / 300

All dimensions are nominal in accordance with DIN 30760, colours are subject to deviation.

\*DU 120 - 360 l Standard with external wheels, DU 120 l alternatively also available with recessed wheels.

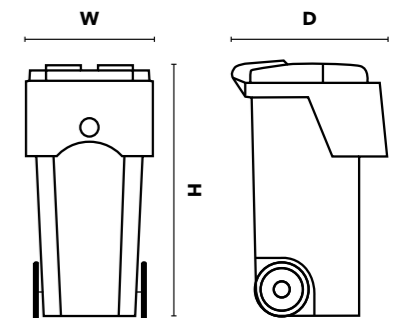

### Standard Bin Colours

Black grey RAL 7021	Rape yellow RAL 1021	Pale brown RAL 8025	Green to RAL-Design 150 40 20 (140 40 20)	Blue to RAL-Design 270 40 40
------------------------	-------------------------	------------------------	--	---------------------------------

# Blue Angel (Blauer Engel)

- Environmentally friendly production process with optimal use of recycled materials
- All containers undergo the same testing requirements - the strictest in the world in accordance with DIN EN 840 and RAL GZ 951/1 - and guarantee a high-quality and durable product
- Certified raw material suppliers (EuCertPlast certificate), which are recertified annually
- The recycle (100% usable in production) consists of at least 80% recycled post-consumer Polyethylene plastic; the remaining percentages are environmentally compatible processing aids and UV stabilizers
- Waste and recycling containers with a capacity of 60 - 360 litres are available with the "Blue Angel" environmental label



Logo as injection molding in the lid

## PRO Wave & Blue Angel Resource conservation and sustainability par excellence:

- At least 80% recycled content
- Very low container weight conserves additional resources
- CO<sub>2</sub> avoidance



### What is the meaning of the Blue Angel?

Many consumers ask themselves the question: "What can be purchased with a clear conscience?" With each purchase of a product or service, you decide directly or indirectly about the impact on water, soil, air or your own health. In order to make your purchasing decisions in terms of environmental factors, you need reliable and trustworthy information about a product's effects on the environment and health. This is precisely where the Blue Angel can help.

The Blue Angel guarantees that the products and services meet high environmental, health and performance standards. In providing this guarantee, the entire life cycle is always considered in the evaluation. For each product group, criteria are developed that must be fulfilled by products and services marked with the Blue Angel. In order to reflect technological developments, the Federal Environmental Agency reviews the criteria every three to four years. In this way, companies are required to make their products more environmentally friendly.

Source: [www.blauer-engel.de](http://www.blauer-engel.de)

# Smart Bins

Smart bins set new benchmarks in the interaction and communication between the citizen, waste contractor and municipality/council. Due to the integration of these three different levels of communication every SSI SCHAEFER Plastics bin becomes an intelligent bin - and this is the new standard.

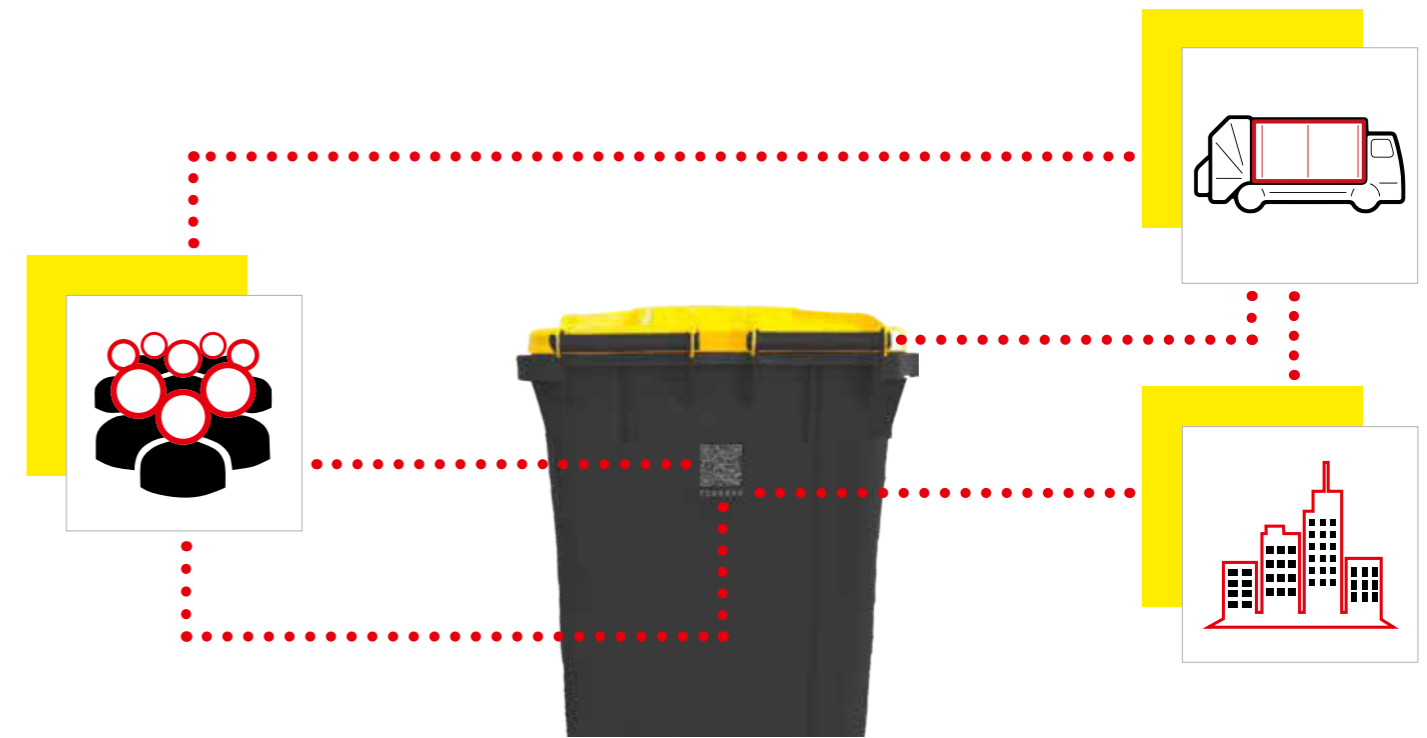

## RFID

A **UHF RFID label** fitted in the lid handle allows identification of the bin by the vehicle. This enables easy route planning and the provision of billing-relevant records to the municipality/council.



## Serial Number

The **alphanumeric number** which is laser coded on the bin can be used if the RFID chip is not activated by the municipality/council or contractor. This number is unique and different for every single bin and it enables the citizen, contractor and municipality to register the bin to an address so that any communication between each other relating to the bin is easier.



## QR-Code

The **QR code** can be linked to a specific webpage/website of the waste disposal company or Local Authority e.g. for the web store, service on demand, collection calendar or citizen portal. The alphanumeric number is unique to the bin and allows the citizen to identify their own bin and also identifies the citizen's bin in the web-portal.

# PLASTIC CONTAINERS MGB

660 - 1,100 litres

- Easy handling and safe functioning in accordance with DIN EN 840-6
- Wheels: solid rubber tyres, individual swivel wheels of 200 mm Diameter, with wheel stop
- Open grips arranged on all sides
- Compatible with all common standardised vehicle mounted lifting devices made in conformity to EU guidelines
- Automatic opening and closing of the lid during the emptying process
- Prepared for the fitting of chips for identification and weighing
- Domed lid with special opening linkages reduces wind scatter problems during emptying
- Domed lid and flat lid containers can be supplied as lid in lid
- High level of safety thanks to integrated child safety lock as protection against unintentional closing of the lid
- Compact injection moulded from high molecular Polyethylene (HDPE)
- Ergonomically fitted handles for comfortable handling
- With water drain hole

MGB plastic	Flat lid 660 l	Flat lid 770 l	Flat lid 1,100 l	Round lid 1,100 l
Width mm (W)	1,370 ± 10	1,370 ± 10	1,370 ± 10	1,370 ± 10
Height mm (H)	1,250 max.	1,370 max.	1,470 max.	1,470 max.
Depth mm (D)	780 max.	800 max.	1,115 max.	1,115 ± 130 max.
Nominal volume l	660 ± 5%	770 ± 5%	1,100 ± 5%	1,100 ± 5%
Payload kg	264	308	440	440
Wheel - Ø mm	200	200	200	200

All dimensions are nominal in accordance with DIN EN 840.

## Standard Bin Colours

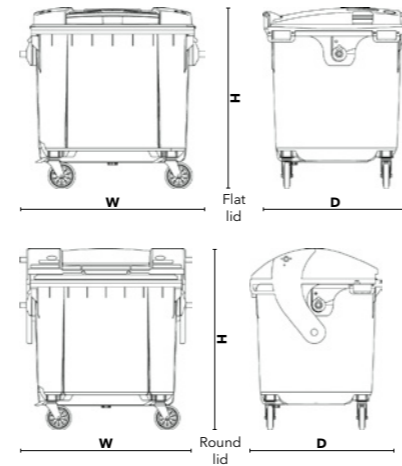

# STEEL CONTAINERS

1,100 litres

## Modultainer

- Robust construction provides high loading capacity
- Long service life and corrosion protection by hot-dip galvanized steel
- Made in compliance with DIN EN 840-2
- Low empty weight
- Compatible with all common standardised lifting devices
- No child safety device necessary
- Easily replaceable plastic lids
- Solid, manoeuvrable wheels with wheel brakes
- Tapered shape for stacking
- Integrated comb lift bar

Modultainer®	1,100 l
Width mm (W)	1,370 ± 10
Height mm (H)	1,470 max.
Depth mm (D)	1,115 max.
Nominal volume l	1,100 ± 5%
Payload kg	440
Wheel - Ø mm	200

All dimensions are nominal in accordance with DIN EN 840-2.

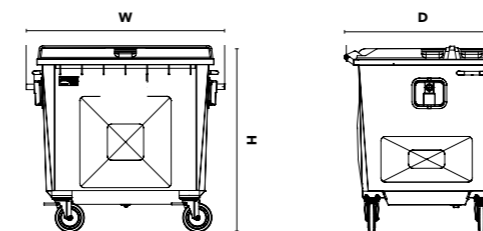

## MGB Steel

- Safety lid fitted as standard with patented child safety device according to the standard DIN EN 840
- Low empty weight
- High stability due to statically calculated embossed panels
- Guaranteed long term reliability
- Wheels with wheel stop
- Very long service life, made of hot-dip galvanized steel
- Compatible with all common standardised lifting devices fitted to vehicles and compactors
- Safe when used in locations of high fire risk such as workshops and industry plants

MGB Steel	1,100 l
Width mm (W)	1,370 ± 10
Height mm (H)	1,470 max.
Depth mm (D)	1,115 max.
Nominal volume l	1,100 ± 5%
Payload kg	440
Wheel - Ø mm	200

All dimensions are nominal in accordance with DIN EN 840-3.

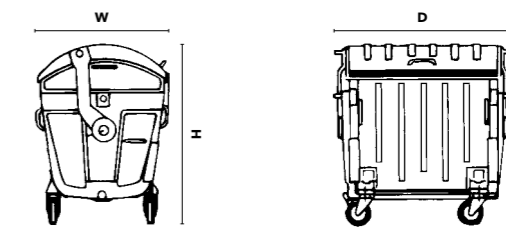

# DEPOT CONTAINER SSI SCHAEFER Plastics

For the central collection of scrap glass, waste paper, light packaging materials, textiles, residual waste and electronic scrap.

## Benefits

- 20 SSI SCHAEFER Plastics depot containers can be emptied within 1 hour compared to 12 standard depot containers which means 66% more efficiency
- Basic modular system, which can always be quickly converted from one version to another
- All depot containers can be divided into two separate chambers by the use of dividing walls, so that two different types of recyclable material can be simultaneously collected in one container
- Highly economical, quick and easy emptying in efficient one-man operation according to the proven system from SSI SCHAEFER Plastics
- Exceptionally strong and long-lasting container
- Quality "Made in Germany", manufactured from steel sheet, hot-dip galvanized in a full bath, on request with additional paint finish
- Colour coded corners and information stickers to identify the recyclable material
- Automatically closing flaps in the apertures protect against fire and water ingress
- Easy conversion, e. g. from a glass to a paper container or from a single-chamber to a multi-chamber container
- Additional sound reduction through the optimal low reach of the crane when the container is discharged
- Special versions for oversize and bulky packaging waste



SSI SCHAEFER Plastics standard opening device



Combination opening device for operation with SSI SCHAEFER Plastics system and "Two Hook" system containers

Depotcontainer	3,2 m <sup>3</sup>
Width mm (W1 / W2)	1,500 / 1,200
(Depth mm (D1 / D2)	1,500 / 1,200
Height mm (H)	1,675
Paper aperture	940 x 110
Nominal capacity m <sup>3</sup>	3,2

All dimensions are approximate following the DIN 13071.

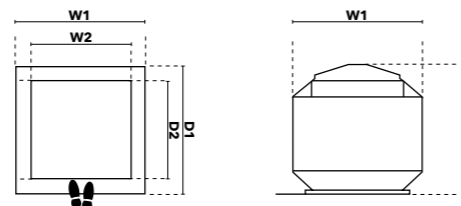

## Standard version

- Single-chamber container
- Container sizes: 3,2 m<sup>3</sup>
- Container made of galvanised sheet steel
- Apertures for paper and glass

## Extras

- Partitions for 2-chamber systems
- Noise reduction class 1
- Painting

# NOISE REDUCTION - WE ARE BETTER THAN THE STANDARD!



- Polyurethane foam covered walls, insulating mats inside the top of the containers and fitting the containers with elastic aperture flaps as well as plastic coated "breakfall" chains
- The test report of the sound technology department of the BeSB GmbH Berlin confirms that the emission values for the insertion of glass bottles are even lower than the noise limits stipulated for Class 1 by the Federal Department of the Environment. The Department of the Environment grades this system as "lacking noise"
- The effective action of the crane loading mechanism on the collection vehicle guarantees additional noise reduction during the discharging operation
- This system achieves a maximum low level reach of the container, and this results in a quiet discharge of the container close to the floor of the vehicle
- Ideally suited to a 2 shift operation
- Short pay back period for cost of the system

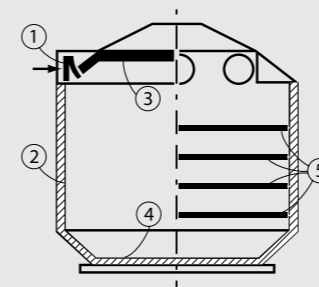

1. Elastic aperture flaps in rubber
2. Foam covering of the walls
3. Insulating mat at the top
4. Insulating material at the bottom
5. Plastic covered "breakfalls"

## Single-chamber system

- Collection of one waste stream
- Recommended for sites with high waste accumulation of one waste stream

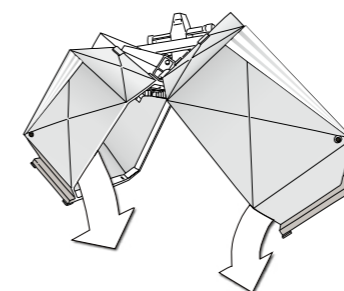

## Multi-chamber system

- Collection and separation of different materials
- Container can be divided in two chambers by means of chamber walls
- Easy retrofitting of chamber walls

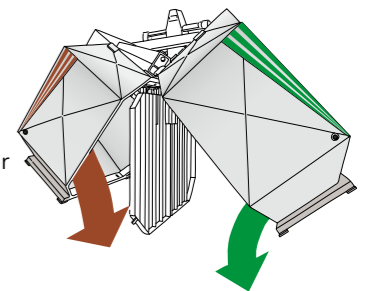

Depot container with glass aperture

# Six reasons why your decision in favor of for SSI SCHAEFER Plastics is the right one:

## 1. Security

As a financially independent family business, SSI SCHAEFER Plastics thinks long-term and you can rely on our team of experts to be there for you today, tomorrow and the day after tomorrow.

## 2. Economic efficiency

The solutions from SSI SCHAEFER Plastics are expandable and grow with your requirements. The modular structure of the solutions allows you to upgrade at any time or to modernize your processes step by step.

## 3. Quality

As an expert in the recycling industry with its own development and production facilities, SSI SCHAEFER Plastics provides you with a wide range of high-quality solutions from a single source. Targeted quality management in accordance with recognized standards ensures the high reliability and resilience of our products. This is also confirmed by independent inspection bodies.

## 4. Reliability

With our own Customer Service & Support, SSI SCHAEFER Plastics guarantees the smooth functioning of your systems and processes, both during and after implementation.

## 5. Know-how

For decades, SSI SCHAEFER Plastics has been a pioneer in the development of disposal systems and sets new standards with innovations and high quality and in the waste disposal industry.

## 6. Digitization

SSI SCHAEFER Plastics Solutions are always state of the art. Our digital experts design comprehensive, demand-oriented system solutions and modular concepts that seamlessly integrate into your existing structures and generate direct added value.

SSI SCHAEFER Plastics GmbH  
Friedrich-Flick-Straße 4  
57299 Burbach | Germany  
info@ssi-plastic.com  
ssi-plastic.com

